



## SURFCOM TOUCH Series

# Excellent Op Sophisticated



# erability and User Interface





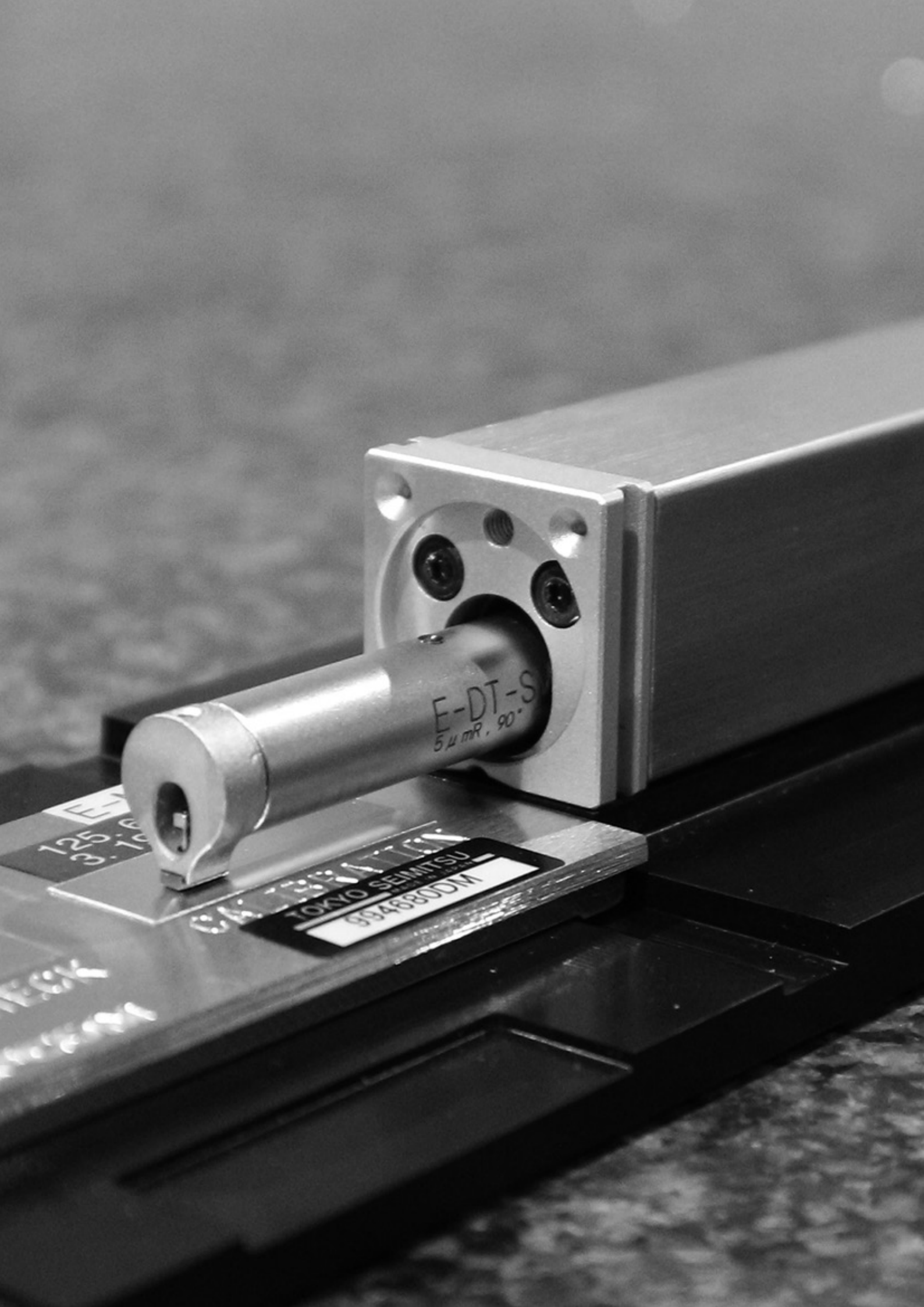

E-DT-S  
5 μmR, 90°

TOKYO SEIMITSU  
984680DM

125.10  
13.10

100

# SURFCOM TOUCH 35/40/45

## Portable-type entry model in the SURFCOM TOUCH series useful in any measurement situation

**Small and light tracing drivers selectable for application. In addition to horizontal surface, measurement on vertical surface with the driver and in narrow areas with transverse trace can be performed. Skid-measurement-type for measurement with different attitudes.**



**Palm-sized(Handy sized) tracing drivers selectable for workpieces and measurement areas**



### 35 (Standard type)

The standard-type with different attitudes to measure horizontal, inclined, vertical and ceiling surfaces.



### 40 (Retraction type)

Retract-type that reduces damage to the stylus and pick-up by raising the pick-up while waiting for measurement or at ending. It can be used as a detector incorporated into an automatic machine.



### 45 (Horizontal tracing type)

The transverse trace-type where the pick-up moves sideways. Narrow areas, such as crankshaft pins and journals, that were difficult to measure before can now be measured.

**A calibration table provided as standard accessory makes calibration work easy**

A roughness specimen for surface texture and a driver selected above are set to the standard calibration table. Calibration can be conducted easily without need of height and inclination adjustment of the driver as before.



**Optional pick-ups allow for various types of measurement**

The pick-up, that comes in contact with the workpiece is replaceable. Various types of workpieces can be measured by using optional pick-ups such as those for small or extremely small holes, deep grooves, etc.



# SURFCOM TOUCH 50

## High-level compact-type model in the SURFCOM TOUCH series with high resolution and straightness

The skidless measurement-type with a high performing pick-up having high resolution and wide range. Various types of workpieces can be measured by changing the stylus for deep, long, or small holes or round surface.

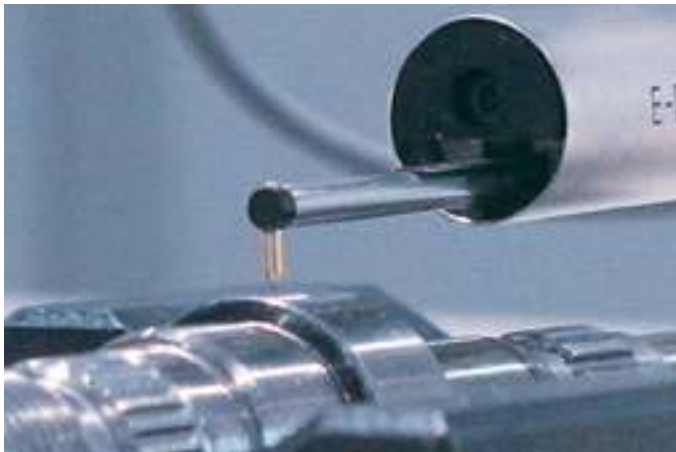

**Extended Z-axis measurement range from 800 to 1,000  $\mu\text{m}$  (25% increase)**



The high performing pick-up with a measurement range of 1,000  $\mu\text{m}$  and a Z-axis minimum resolution of 0,0001  $\mu\text{m}$  allows for wide-range and high resolution skidless measurement. No need to consider measurement range. In addition to flat surfaces, the roughness or waviness on undulating surfaces such as stepped or round surfaces can be evaluated with one trace. Levelling and zeroing before measurement can also be performed easily.



**A compact high performing tracing driver**

The portable compact size tracing driver for easy instalment has an X-axis measurement range of 50 mm, a straightness accuracy of 0.3  $\mu\text{m}/50$  mm, and a detector vertical movement volume of 50 mm.

Safe positioning at a constant speed is possible by operating the tracing driver in the X direction from the screen of the amplifier.

**A handy-type driver can be attached**

SURFCOM TOUCH 50 can be connected with a handy-type tracing driver\*.

Measurement on vertical or ceiling surface and in narrow areas can be performed.



\*Tracing driver attached to SURFCOM TOUCH 35/40/45, HANDYSURF E-35B/40A/45A, and SURFCOM FLEX-35B/40A/45A. An optional dedicated cable is required for connection.

**Suited for measuring cylindrical workpieces. A tracing driver can be placed on workpieces by using an optional roll footing.**

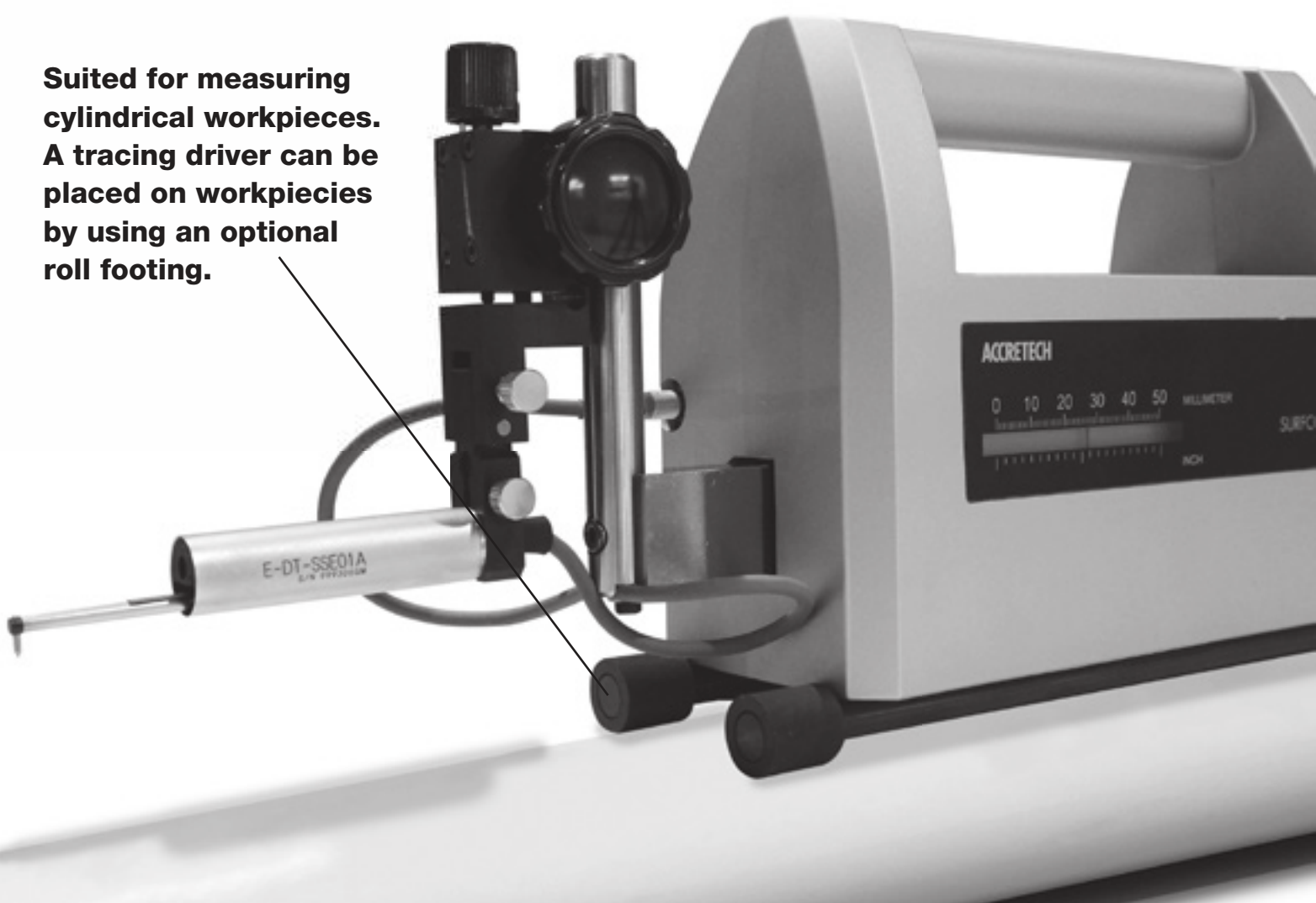

**An optional compact measurement stand for measuring high workpieces or measuring with jigs.**

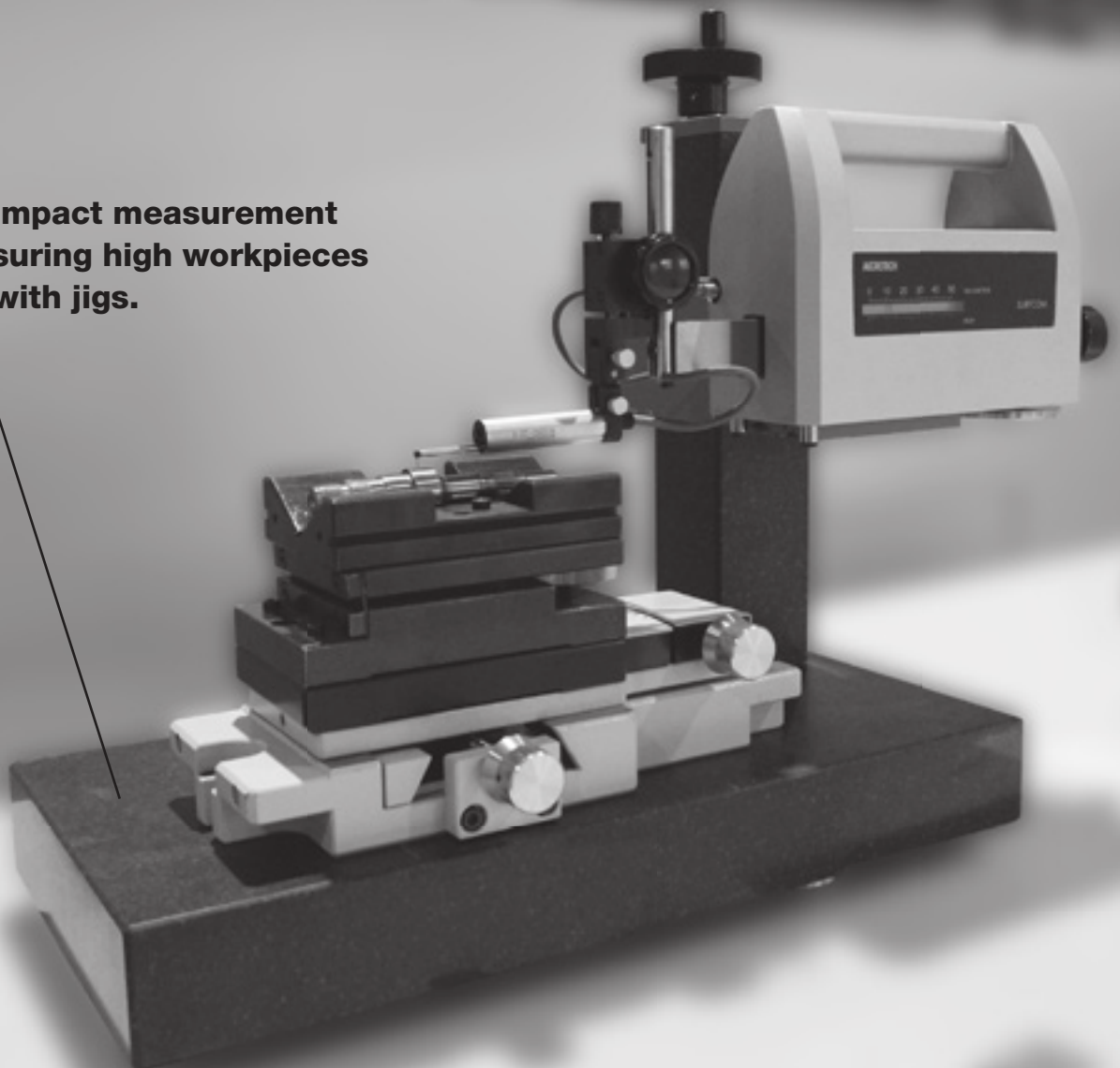







# SURFCOM TOUCH 550

## High-end model in the SURFOM TOUCH series with an electric column offering high accuracy and size variation

Equipped with a high performing pick-up having high resolution and wide range. It offers high flexibility where granite base size, column height, and X-axis drive range can be selected depending on needs.



**Extended Z-axis measurement range from 800 to 1,000  $\mu\text{m}$  (25% increase)**



The high performing pick-up with a measurement range of 1,000  $\mu\text{m}$  and a z-axis minimum resolution of 0,0001  $\mu\text{m}$  allows for wide-range and high resolution skidless measurement. No need to consider measurement range. In addition to flat surfaces, the roughness or waviness on undulating surfaces such as stepped or round surfaces can be evaluated with one trace. Levelling and zeroing before measurement can also be performed easily.

### Large-sized electric column

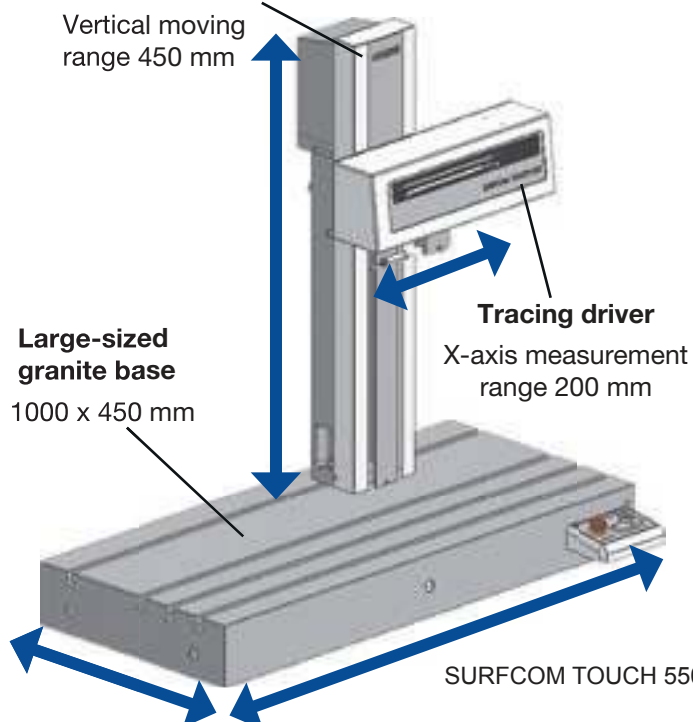

### Size variations for various types of workpieces

SURFCOM TOUCH 550 allows users to select a combination of the size of the granite base, the height and type of the column and the drive range in the X axis direction. (refer to p.15)

This meets diverse customer needs such as "we want to reduce the installation space", "we want to reduce initial costs", "we want to measure high workpieces" and "we want to measure large flat workpieces".

# SURFCOM TOUCH Common Functions

## Intuitive and easy-to-use screen for condition setting, calibration, measurement and analysis

An amplifier with a 7-inch wide touch panel and easy-to-use new interface provides higher operability. Easy-to-use operation eliminates the need of instructions.

### Control screen of the driver



- It shows the level meter (Z) (contact level of the stylus with the workpiece), and horizontal (X) and vertical (C) positions of the tracing driver. (Z is shown on all models, X on TOUCH 50/550, C on TOUCH 550)
  - The pick-up can be moved horizontally and the tracing driver can be moved vertically from the screen. (TOUCH 50 can move the pick-up, and TOUCH 550 can move the pick-up and tracing driver)
- Two moving speeds are available for selection.

### Main Screen

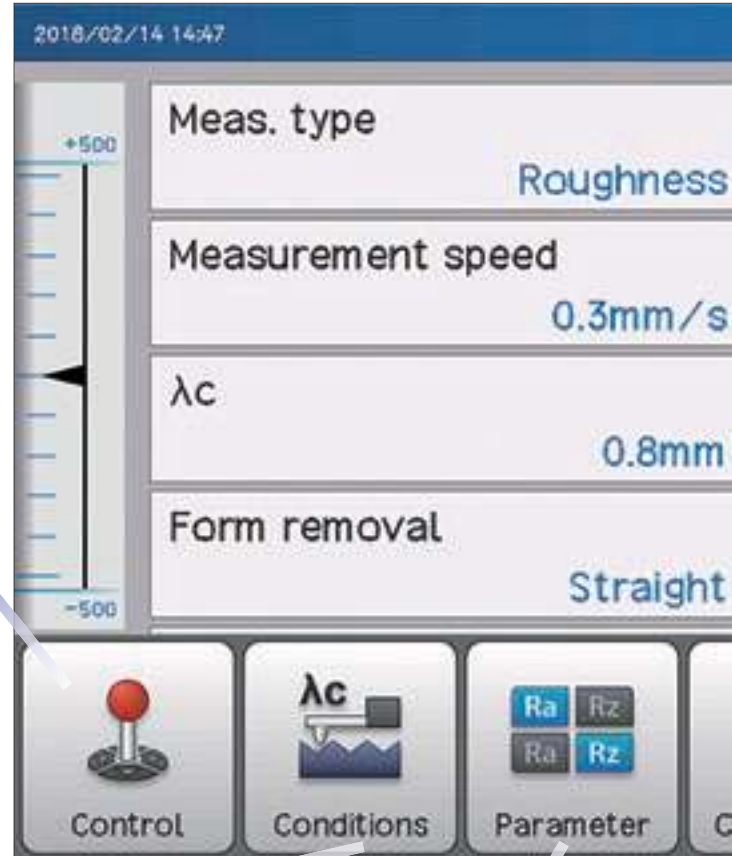

### Setting Condition Screen

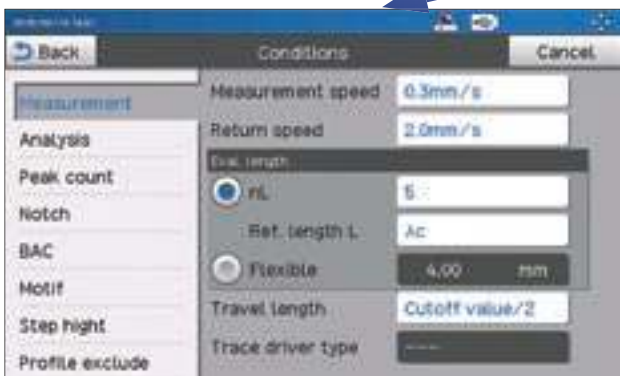

- Measurement/analysis conditions can be set.

### Parameter Selection Screen



- Parameters to be evaluated in measurement can be selected.

**Menu Screen**



- Settings can be performed such as language, icon layout, management of internal/USB memories.

**Output Item Screen**

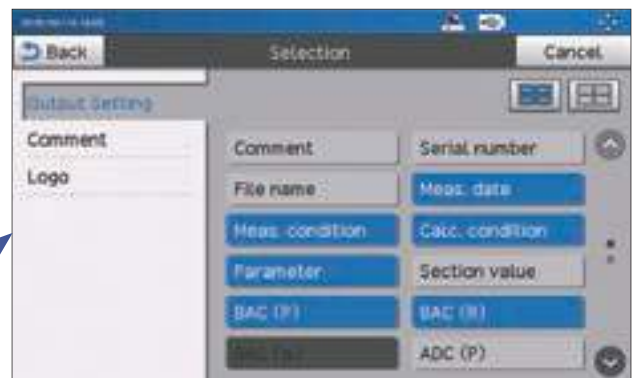

- Output items can be set for printing with the small printer attached to SURFCOM TOUCH\*.

\*Some TOUCH 35, 40, 45 and 50 types have no printer.



**Calibration Screen**



- Calibration can be performed before measurement.
- Any wear or chip of the stylus tip can be checked with the waveform and values.

**Measurement Result Screen**



- Measurement results are shown in waveform and selected parameters. Horizontal and vertical display magnification for waves can be changed intuitively with zoom-in or zoom-out by fingers. No need to specify magnification in number (although it is also possible).
- OK/NG is easily identified by setting acceptance/rejection criteria in advance.



# SURFCOM TOUCH Common Functions

## Multi-language support available worldwide

20 Asian and European languages including Japanese, English and German are provided as standard. Language can be changed easily with one touch.



### Supported Language



Display example in (simplified) Chinese



Display example in Japanese



Display example in Thai



Display example in Vietnamese

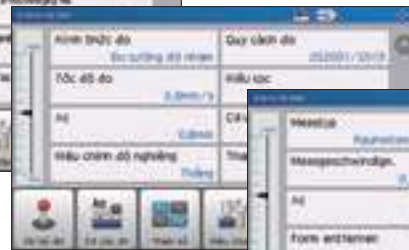

Display example in German



## Easy-to-follow user's guide/quick reference guide

The user's guide is easy to understand like that for home appliances.

A quick reference guide showing basic operation procedures is also available so that users do not need to create written procedures.

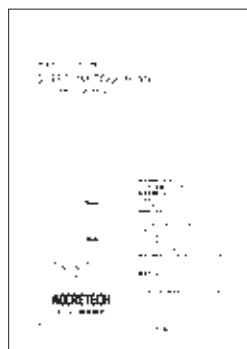

User's guide (left) and quick reference guide (right)

## USB/micro USB ports as standard equipment

15 measurement conditions and 20 measurement results can be stored in the SURFCOM TOUCH amplifier. More conditions and results can be stored by connecting a USB memory to the standard USB port.

The amplifier is also equipped with a micro USB port. Measurement data can be transferred to the computer when connected with a USB cable, and a simple inspection report can be created using attached SupportWare II.

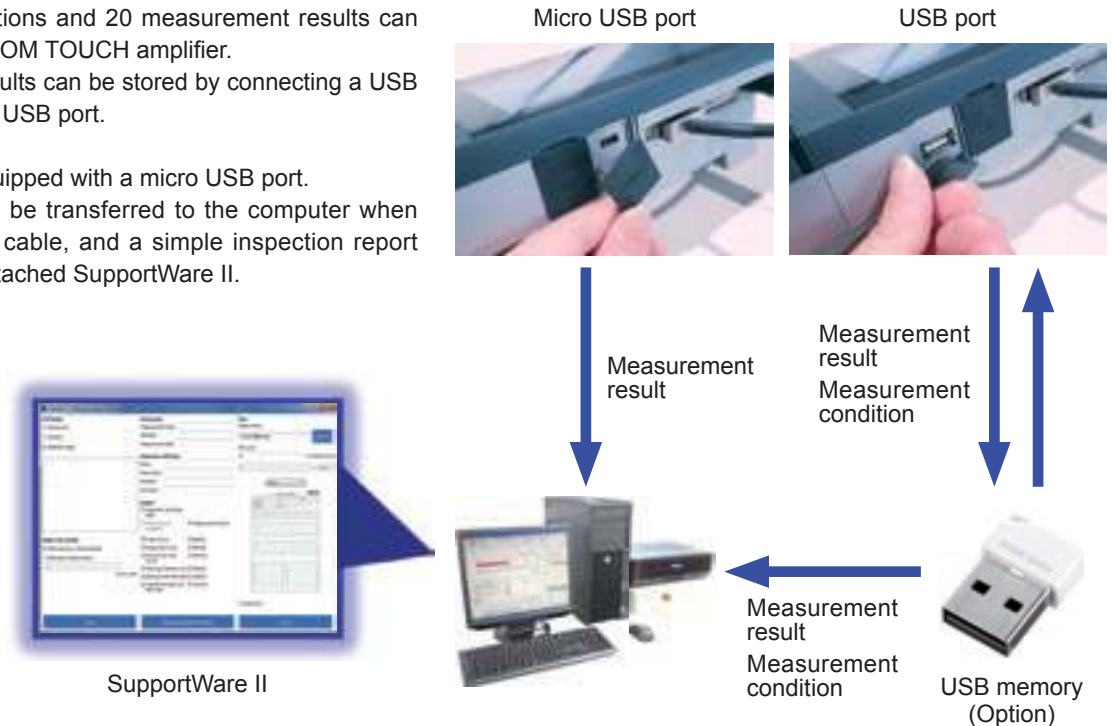

## Measurement results can be printed quickly

The dedicated printer allows for quick printing of measurement results. Of course, any measurement data saved in the amplifier or USB memory can be output.

- TOUCH 550 has a built-in printer.
- TOUCH 35 to 50 have two models: with/without printer  
Models without printer can be connected with an external printer unit.

Measurement results output example

ACCURETECH Ver.1.15 SURFCOM TOUCH 550	<Roughness profile>
Comment =	V-mag. = 2000 (AUTO)
Serial No. = 3	H-mag. = 20 (AUTO)
File name = MEASDATA	V-scale = 5µm/10mm
Date = 18.02.16	H-scale = 500µm/10mm
Time = 16:09:53	
Roughness measurement (JIS2001/2013)	
Eval. length = 4.00mm	
Samp. length = λc	
Meas. speed = 0.30mm/s	
λc = 0.8mm	
Cutoff type = Gaussian	
Meas. range = ±500.0µm	
Form removal = Straight	
As = 2.5µm	
Polarity inv = OFF	
Pickup Type = Standard	

TOUCH 550



With a built-in printer

TOUCH 35 to 50



Printer-equipped model



Model without printer



Model without printer and a printer unit (optional)

# SURFCOM TOUCH 35/40/45 Specifications

Model		SURFCOM TOUCH					
		35		40		45	
		Tip radius 5 μm	Tip radius 2 μm	Tip radius 5 μm	Tip radius 2 μm	Tip radius 5 μm	
Measurement range	Z direction	-210 to +160 μm					
	Drive axis	X direction 16 mm				Y direction 4 mm	
Tracing driver	Movement type	Standard type			Retraction type		
	Evaluation length	0.2 to 16 mm					
	Measurement speed	0.5, 0.6, 0.75, 1.0 mm/s				0.6 mm/s	
Pick-up	Sensing type	Differential inductance					
	Measurement method	Skid					
	Z direction resolution	0.0007 μm/-210 to 160 μm					
	Model	E-DT-SM10A	E-DT-SM49A	E-DT-SM10A	E-DT-SM49A	E-DT-SM39A	
	Stylus	Measurement force	4 mN	0.75 mN	4 mN	0.75 mN	4 mN
Tip radius		r <sub>tip</sub> = 5 μm	r <sub>tip</sub> = 2 μm	r <sub>tip</sub> = 5 μm	r <sub>tip</sub> = 2 μm	r <sub>tip</sub> = 5 μm	
Tip angle		90° cone	60° cone	90° cone	60° cone	90° cone	
Tip material		Diamond					
Analysis item	Calculation standards	Comply with JIS2013/2001, JIS1994, JIS1982, ISO1997/2009, ISO13565, DIN1990, ASME2002/2009, ASME1995, CNOMO					
	Parameter	Profile curve	Pa, Pq, Pp, Pv, Pc, PSm, PΔq, PPc, Psk, Pku, Pt, Pmr(c), Pmr, Pδc, Rz82, TILTA, AVH, Hmax, Hmin, AREA, Rmax, Rz, Sm, Δa, Δq, λa, λq, Lr, Rsk, Rku, Rk, Rpk, Rvk, Mr1, Mr2, Vo, K, tp, tp2, Hp				
		Roughness curve	Ra, Rq, Rz, Rv, Rc, Rt, RSm, RΔq, Rsk, Rku, Rmr(c), Rmr, Rδc, Rz94, R3z, RΔa, Rλa, Rλq, Ry, Lr, Sm, S, tp, tp2, PC, RPe ISO, RPe EN, Pc, PPI, Rp, Rmax, Rz.l, RS, Rmr2, Mr1, Mr2, Rpk, Rvk, Rk, Vo, K, A1, A2, Rpm, Δa, Δq, Htp				
		Motif	R, Rx, AR, W, Wx, AW, Rke, Rpk, Rvke, NCRX, NR, CPM, SR, SAR, Wte, NW, SAW, SW, Mr1e, Mr2e, Vo, K				
	Evaluation curve	Profile curve, roughness curve, ISO13565 special roughness curve, waviness motif curve, upper envelope waviness curve					
Characteristics graph	Abbot curve, amplitude density function, power graph						
Filter	Filter type	Gaussian, 2RC (phase compensation), 2RC (non-phase compensation)					
	Cut-off value	Ac	0.08, 0.25, 0.8, 2.5 mm				
		As	None, 2.5, 8, 25 μm				
Amplifier	Display	7-inch colour liquid crystal touch panel					
	Data output	USB connectors for USB memory : x 2 (model without printer), x 1 (model with printer), Micro USB connector for USB communication x 1					
	Print output	Standard function for models with printer and optional for models without printer (external printer unit)/Thermal recording paper width: 58 mm (recording width: 48 mm)					
	Language	Japanese, English, Chinese (Traditional Chinese/Simplified Chinese), Korean, Thai, Malay, Vietnamese, Indonesian, German, French, Italian, Czech, Polish, Hungarian, Turkish, Swedish, Dutch, Spanish, Portuguese					
Specifications	Power supply	Charging	Built-in battery (to be charged using AC adaptor), charging period: 3 hours (about 600 measurements can be take when fully charged)				
		Power supply	AC100 to 240 V ±10%, 50/60 Hz, single phase				
	Power consumption	Maximum 80VA					
	External dimensions (W x D x H)/Weight	Printer-equipped model	Amplifier: 320 x 167 x 44 mm/about 2 kg for the entire system				
		Models without printer	Amplifier: 252 x 167 x 44 mm/about 1.6 kg for the entire system				
Standard accessories		Roughness specimen (E-MC-S24C), calibration table (E-WJ-S1045A), touch pen (E-MA-S112A), printing paper (E-CH-S25A)*1, instruction manuals, SupportWare II nose-piece (V-type) (E-WJ-S536A)*2					

\*1 For models with printer only  
\*2 For SURFCOM TOUCH 45 only

# SURFCOM TOUCH 50 Specifications

Model		SURFCOM TOUCH		
		50		
Measurement range	Z direction	±500 μm		
	X direction	50 mm		
Tracing driver	Evaluation length	0.1 to 50 mm		
	Straightness accuracy	0.3 μm/50 mm		
	Detector vertical movement volume	50 mm		
	Measurement Speed	0.15, 0.3, 0.6, 1.5, 3 / 0.05, 0.1, 0.2, 0.5, 1 mm/s (switching)		
Pick-up	Sensing type	Differential inductance		
	Measurement method	Skidless/Skid (optional)		
	Z direction resolution	0.0001 μm/±40 μm, 0.00125 μm/±500 μm		
	Stylus (standard accessory)	Model	DM43801	
		Measurement force	0.75 mN	
Radius		r <sub>tip</sub> = 2 μm		
Angle		60° cone		
Material	Diamond			
Analysis item	Calculation standards	Comply with JIS2013/2001, JIS1994, JIS1982, ISO1997/2009, ISO13565, DIN1990, ASME2002/2009, ASME1995, CNOMO		
	Parameter	Profile curve	Pa, Pq, Pp, Pv, Pc, PSm, PΔq, PPc, Psk, Pku, Pt, Pmr(c), Pmr, Pδc, Rz82, TILTA, AVH, Hmax, Hmin, AREA, Rmax, Rz, Sm, Δa, Δq, λa, λq, Lr, Rsk, Rku, Rk, Rpk, Rvk, Mr1, Mr2, Vo, K, tp, tp2, Hp	
		Roughness curve	Ra, Rq, Rz, Rv, Rc, Rt, RSm, RΔq, Rsk, Rku, Rmr(c), Rmr, Rδc, Rz94, R3z, RΔa, Rλa, Rλq, Ry, Lr, Sm, S, tp, tp2, PC, RPe ISO, RPe EN, Pc, PPI, Rp, Rmax, Rz.l, RS, Rmr2, Mr1, Mr2, Rpk, Rvk, Rk, Vo, K, A1, A2, Rpm, Δa, Δq, Htp	
		Waviness profile curve	Wa, Wq, Wt, Wp, Wv, WSm, WPC, Wsk, Wmr(c), Wmr, Wδc, Wz, Wc, Wku, WΔq, WEM, WEA, WE-a, WE-q, WE-p, WE-v, WE-Sm, WEC-q, WEC-m, WEC-p, WEC-v, WEC-Sm	
	Motif	R, Rx, AR, W, Wx, AW, Rke, Rpk, Rvke, NCRX, NR, CPM, SR, SAR, Wte, NW, SAW, SW, Mr1e, Mr2e, Vo, K		
Evaluation curve	Profile curve, roughness curve, filtered waviness curve, waviness profile curve, ISO13565 special roughness curve, roughness motif curve, waviness motif curve, upper envelope waviness curve, rolling circle waviness curve			
Characteristics graph	Abbot curve, amplitude density function, power graph			
Filter	Filter type	Gaussian, 2RC (phase compensation), 2RC (non-phase compensation)		
	Cut-off value	Ac	0.08, 0.25, 0.8, 2.5, 8, 25 mm	
		As	None, 2.5, 8, 25 μm	
Amplifier	Display	7-inch colour liquid crystal touch panel		
	Data output	USB connectors for USB memory : x 2 (model without printer), x 1 (model with printer), Micro USB connector for USB communication x 1		
	Print output	Standard function for models with printer and optional for models without printer (external printer unit)/Thermal recording paper width: 58 mm (recording width: 48 mm)		
	Language	Japanese, English, Chinese (Traditional Chinese/Simplified Chinese), Korean, Thai, Malay, Vietnamese, Indonesian, German, French, Italian, Czech, Polish, Hungarian, Turkish, Swedish, Dutch, Spanish, Portuguese		
Specifications	Power supply	Charging	Built-in battery (to be charged using AC adaptor), charging period: 3 hours (about 600 measurements can be take when fully charged)	
		Power supply	AC100 to 240 V ±10%, 50/60 Hz, single phase	
	Power consumption	Maximum 80 VA		
	External dimensions (W x D x H)/Weight	Printer-equipped model	Amplifier : 320 x 167 x 44 mm/about 4.2 kg for the entire system	
		Models without printer	Amplifier : 252 x 167 x 44 mm/about 3.8 kg for the entire system	
Standard accessories		Roughness specimen (E-MC-S24C), touch pen (E-MA-S112A), printing paper (E-CH-S25A)*1, instruction manuals, SupportWare II		

\*1 For models with printer only



## SURFCOM TOUCH 550 Specifications

Model		SURFCOM TOUCH									
		550									
		-11	-12	-13	-14	-21	-22	-23	-24		
Measurement range	Z direction	±500 µm									
	X direction	100 mm				200 mm					
Tracing driver	Drive distance	100 mm				200 mm					
	Straightness accuracy	(0.05 + 1.5L/1000) µm (L: measurement length (mm))									
	Speed	0.03, 0.06, 0.15, 0.3, 0.6, 1.5, 3, 6 / 0.05, 0.1, 0.2, 0.5, 1, 2, 5 mm/s (switching)									
Pick-up	Sensing type	Differential inductance									
	Measurement method	Skidless/Skid (optional)									
	Z direction resolution	0.0001 µm/±40 µm, 0.00125 µm/±500 µm									
	Stylus (standard accessory)	Model	DM43801								
		Measurement force	0.75 mN								
		Radius	r <sub>sp</sub> = 2 µm								
		Angle	60° cone								
Material		Diamond									
Measurement stand	Column	Drive distance	250 mm		450 mm		250 mm		450 mm		
		Moving speed	-- (Manual)	to 3 mm/s (when operating the amplifier touch panel), to 10 mm/s (when using the joystick)			-- (Manual)	to 3 mm/s (when operating the amplifier touch panel), to 10 mm/s (when using the joystick)			
	Base	Size	600 mm x 317 mm			1000 mm x 450 mm		600 mm x 317 mm		1000 mm x 450 mm	
		Material	Granite								
	Maximum allowable load weight*1		Approx. 48 kg	Approx. 42 kg	Approx. 33 kg	Approx. 48 kg	Approx. 43 kg	Approx. 37 kg	Approx. 28 kg	Approx. 43 kg	
Analysis item	Calculation standards		Comply with JIS2013/2001, JIS1994, JIS1982, ISO1997/2009, ISO13565, DIN1990, ASME2002/2009, ASME1995, CNOMO								
	Parameter	Profile curve	Pa, Pq, Pp, Pv, Pc, PSm, PΔq, PPc, Psk, Pku, Pt, Pmr(c), Pmr, Pδc, Rz82, TILTA, AVH, Hmax, Hmin, AREA, Rmax, Rz, Sm, Δa, Δq, Δa, Δq, Lr, Rsk, Rku, Rk, Rpk, Rvk, Mr1, Mr2, Vo, K, tp, tp2, Hp								
		Roughness curve	Ra, Rq, Rz, Rv, Rc, Rt, RSm, RΔq, Rsk, Rku, Rmr(c), Rmr, Rδc, Rz94, Rz3z, RΔa, RΔa, RΔq, Ry, Lr, Sm, S, tp, tp2, PC, RPe ISO, RPe EN, Pc, PPI, Rp, Rmax, Rz.l, RS, Rmr2, Mr1, Mr2, Rpk, Rvk, Rk, Vo, K, A1, A2, Rpm, Δa, Δq, Htp								
		Waviness profile curve	Wa, Wq, Wt, Wp, Wv, WSm, WPC, Wsk, Wmr(c), Wmr, Wδc, Wz, Wc, Wku, WΔq, WEM, WEA, WE-a, WE-q, WE-p, WE-v, WE-Sm, WEC-q, WEC-m, WEC-v, WEC-Sm								
		Motif	R, Rx, AR, W, Wx, AW, Rke, Rpk, Rvk, NCRX, NR, CPM, SR, SAR, Wte, NW, SAW, SW, Mr1e, Mr2e, Vo, K								
	Evaluation curve		Profile curve, roughness curve, filtered waviness curve, waviness profile curve, ISO13565 special roughness curve, roughness motif curve, waviness motif curve, upper envelope waviness curve, rolling circle waviness curve								
Characteristics graph		Abbot curve, amplitude density function, power graph									
Filter	Filter type		Gaussian, 2RC (phase compensation), 2RC (non-phase compensation)								
	Cut-off value	Ac	0.08, 0.25, 0.8, 2.5, 8, 25 mm								
		As	None, 2.5, 8, 25 µm								
Amplifier	Display	7-inch colour liquid crystal touch panel									
	Data output	USB connector for USB memory x 1, Micro USB connector for USB communication x 1									
	Print output	Standard function/Thermal recording paper width: 58 mm (recording width: 48 mm)									
	Language	Japanese, English, Chinese (Traditional Chinese/Simplified Chinese), Korean, Thai, Malay, Vietnamese, Indonesian, German, French, Italian, Czech, Polish, Hungarian, Turkish, Swedish, Dutch, Spanish, Portuguese									
Specifications	Power supply	AC100 to 240 V±10%, 50/60 Hz, single phase, D-type grounding									
	Power consumption	Maximum 110 VA									
	External dimensions (W x D x H)/Weight	Measurement unit: See the external view below. Amplifier: 340 x 214.5 x 139.5 mm/about 4.1 kg									
Standard accessories		Roughness specimen (E-MC-S24C), levelling adjustment table (E-AT-S02A), touch pen (E-MA-S112A), printing paper (E-CH-S25A), instruction manuals, SupportWare II									

\*1 This maximum allowable load weight is for the case when using the optional anti-vibration table (E-VS-S57B for -11, -12, -13, -21, -22, -23 system, and E-VS-R16B for -14, -24 system)

## SURFCOM TOUCH 550 External view

Model	Dimension of the main body (mm)				Measurement range(mm)		Base (mm)			Weight (kg)			
	Maximum Width	Depth	Height	Column height	X axis (tracing driver)	C axis (column)	Width	Depth	Base height	Column set position	Weight of main body	Maximum load weight*	
	W1	D1	H1	H3	---	---	W2	D2	H2	A	---	---	
SURFCOM TOUCH 550	-11	610	481	667	552	100	250	600	317	115	(140)	89	48
	-12	610	481	738	623	100	250	600	317	115	(140)	95	42
	-13	610	481	938	823	100	450	600	317	115	(140)	104	33
	-14	1000	586	963	823	100	450	1000	450	140	(240)	209	48
	-21	670	481	667	552	200	250	600	317	115	(140)	94	43
	-22	670	481	738	623	200	250	600	317	115	(140)	100	37
	-23	670	481	938	823	200	450	600	317	115	(140)	109	28
-24	1000	586	963	823	200	450	1000	450	140	(240)	214	43	

\* This maximum load weight is for the case when using the optional anti-vibration table (E-VS-S57B for -11/12/13/21/22/23 system, and E-VS-R16B for -14/24 system)

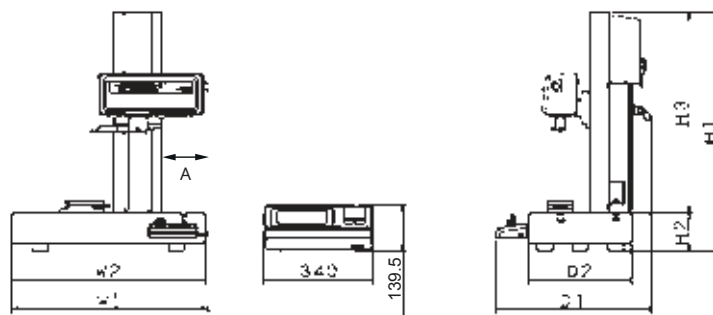



Together with our partners, we are able to offer you a Europe-wide sales and service network. Through the regional proximity, a service technician can reach your premises without any prolonged wait and travel times. If you have any questions, please contact us directly from all European countries through our centralized metrology phone number or email address:



**+49(0)89 54 6788 - 0**

Mon – Fri from 8:30 a.m. to 5:00 p.m.



**sf-g-info@accretech.eu**

#### Germany

Carl Zeiss 3D Metrology Services GmbH Stuttgart  
Felix-Wankel-Str. 6  
73760 Ostfildern  
www.zeiss.de/messtechnik-stuttgart  
Email stuttgart.metrology.de@zeiss.com  
Tel. +49 (0)711 341678-10

#### Austria

ACCRETECH (Europe) GmbH  
www.accretech.eu  
Email sf-g-info@accretech.eu  
Tel. +49 (0)89 54 6788-0

#### Switzerland

ACCRETECH (Europe) GmbH  
www.accretech.eu  
Email sf-g-info@accretech.eu  
Tel. +49 (0)89 54 6788-0

Osterwalder Messtechnik AG  
Sumpfstraße 13  
6312 Steinhausen  
www.osterwalder-zug.ch  
Email info@osterwalder-zug.ch  
Tel. +41 (0)41 748 19 19

#### Italy

ACCRETECH (Europe) GmbH  
Via Giotto, 7  
20032 Cormano  
www.accretech.eu  
Email sf-g-info@accretech.eu  
Tel. +39 02 2316 3291

#### France

ACCRETECH (Europe) GmbH  
14 Chemin des Clos  
38240 Meylan  
www.accretech.eu  
Email sf-g-info@accretech.eu  
Tel. +33 (0)476 044080

#### United Kingdom

Bowers Group  
Unit 3, Albany Court  
Albany Park, Camberley  
Surrey, GU16 7QR  
www.bowersgroup.co.uk  
Email sales@bowersgroup.co.uk  
Tel. +44 (0) 12 7646 9866

#### Ireland

JED Metrology Ltd.  
21 Tolka Valley Business Park  
Glasnevin, Dublin 11  
Email sales@jed.ie  
Tel. +353 1 830 7744

#### Denmark

Carl Zeiss AS  
Blokken 76, 3460 Birkerød  
www.zeiss.dk  
Email info.metrology.dk@zeiss.com  
Tel. +45 7015 7015

#### Sweden

ACCRETECH (Europe) GmbH  
www.accretech.eu  
Email sf-g-info@accretech.eu  
Tel. +49 (0)89 54 6788-0

#### Norway

Carl Zeiss AS  
Kabelgaten 8, 0580 Oslo  
www.zeiss.no  
Email info.metrology.no@zeiss.com  
Tel. +47 2317 2390

#### Finland

Carl Zeiss Oy  
IMT Finland, Niittyvillankuja 4B  
01510 Vantaa  
www.zeiss.fi  
Email info.metrology.fi@zeiss.com  
Tel. +358 (0) 20794 0891

#### Netherlands

ACCRETECH (Europe) GmbH  
www.accretech.eu  
Email sf-g-info@accretech.eu  
Tel. +49 (0)89 54 6788-0

#### Spain

Izasa Scientific S.L.U.  
Plaza Europa 21-23  
08908 L'Hospitalet de Llobregat,  
Barcelona  
www.izasascientific.com  
Email marketing@izasascientific.com  
Tel. +34 902 20 30 80

#### Portugal

Izasa Scientific, LDA  
Rua do Proletariado, 1  
Quinta do Paizinho  
2790-138 Carnaxide, Lisboa  
www.izasascientific.com  
Email marketing@izasascientific.com  
Tel. +351 21 424 73 18

#### Poland

ACCRETECH (Europe) GmbH  
www.accretech.eu  
Email sf-g-info@accretech.eu  
Tel. +49 (0)89 54 6788-0

#### Hungary

ACCRETECH (Europe) GmbH  
Liget utca 3/2 3. Floor  
2040 Budaörs, Hungary  
www.accretech.eu  
Email sf-g-info@accretech.eu  
Tel. +36 23 232 224

#### Bulgaria

ACCRETECH (Europe) GmbH  
www.accretech.eu  
Email sf-g-info@accretech.eu  
Tel. +49 (0)89 54 6788-0

#### Romania

Mark Dimension Technologies S.R.L  
Sos. Stefan cel Mare Nr. 14  
Building 19  
Apartment 46  
020141 Bucharest  
www.markd.ro  
Email office@markd.ro  
Tel. +40 724 629953

#### Slovakia

ACCRETECH (Europe) GmbH  
www.accretech.eu  
Email sf-g-info@accretech.eu  
Tel. +49 (0)89 54 6788-0

#### Slovenia

ACCRETECH (Europe) GmbH  
www.accretech.eu  
Email sf-g-info@accretech.eu  
Tel. +49 (0)89 54 6788-0

#### Czech Republic

ACCRETECH (Europe) GmbH  
www.accretech.eu  
Email sf-g-info@accretech.eu  
Tel. +49 (0)89 54 6788-0

#### Turkey

ACCRETECH (Europe) GmbH  
www.accretech.eu  
Email sf-g-info@accretech.eu  
Tel. +49 (0)89 54 6788-0

We reserve the right to change the contents of this catalog, including product specifications, without notice when products are updated. Some of our products shall be controlled by the Foreign Exchange and Foreign Trade Act, and required an export license by the Japanese Government. Regarding exporting the products and/or providing a non-resident with technologies, please consult ACCRETECH (Tokyo Seimitsu).



**EUROPE**

ACCRETECH (Europe) GmbH  
Landsberger Str. 396, 81241 Munich, Germany  
Phone +49 (0)89 54 67 88 - 0, Fax +49 (0)89 54 67 88 - 10  
sf-g-info@accretech.eu  
www.accretech.eu